

Electronic Modular Switching System

Panasonic

INSTALLATION **M**ANUAL

*Please read this manual before connecting the
Electronic Modular Switching System.*

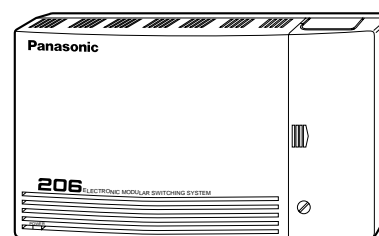

MODEL
KX-T206JT

**Thank you for purchasing the Panasonic Model
KX-T206, Electronic Modular Switching System.**

System Component

	Model No.	Description
Service Unit	KX-T206	Electronic Modular Switching System
Telephone	KX-T7130 KX-T7030 KX-T7020 KX-T7050	Proprietary telephone with display Proprietary telephone with display Proprietary telephone Proprietary telephone
Optional Equipment	KX-T20691 KX-T30865	DISA/FAX Detect Card Doorphone

Notes

- This Installation Manual does not show complete model numbers that indicate the country where your models should be used.
The model number of your unit is found on the label affixed to the unit.

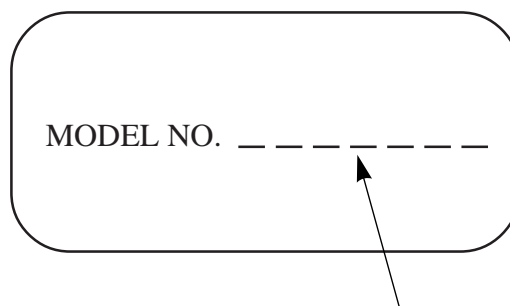

- A proprietary telephone is abbreviated as “PT”.
- A single line telephone is abbreviated as “SLT”.

Precaution

- Keep the unit away from heating appliances and electrical noise generating devices such as fluorescent lamps, motors and television. These noise sources can interfere with the performance of the Electronic Modular Switching System.
- This unit should be kept free of dust, moisture, high temperature (more than 40°C/104°F) and vibration, and should not be exposed to direct sunlight.
- Never attempt to insert wires, pins, etc. into the vents or other holes of this unit.
- If there is any trouble, disconnect the unit from the telephone line. Plug the telephone directly to the telephone line. If the telephone operates properly, do not reconnect the unit to the line until the trouble has been repaired. If the telephone does not operate properly, chances are that the trouble is in the telephone system, and not in the unit.
- Do not use benzine, thinner, or the like, or any abrasive powder to clean the cabinet. Wipe it with a soft cloth.

WARNING

THIS UNIT MAY ONLY BE INSTALLED AND SERVICED BY QUALIFIED SERVICE PERSONNEL.

WHEN A FAILURE OCCURS WHICH RESULTS IN THE INTERNAL PARTS BECOMING ACCESSIBLE, DISCONNECT THE POWER SUPPLY CORD IMMEDIATELY AND RETURN THIS UNIT TO YOUR DEALER.

DISCONNECT THE TELECOM CONNECTION BEFORE DISCONNECTING THE POWER CONNECTION PRIOR TO RELOCATING THE EQUIPMENT, AND RECONNECT THE POWER FIRST.

THIS UNIT IS EQUIPPED WITH AN EARTHING CONTACT PLUG. FOR SAFETY REASONS THIS PLUG MUST ONLY BE CONNECTED TO AN EARTHING CONTACT SOCKET WHICH HAS BEEN INSTALLED ACCORDING TO REGULATIONS.

THE POWER SOCKET WALL OUTLET SHOULD BE LOCATED NEAR THIS EQUIPMENT AND BE EASILY ACCESSIBLE.

TO PREVENT FIRE OR SHOCK HAZARD, DO NOT EXPOSE THIS PRODUCT TO RAIN OR ANY TYPE OF MOISTURE.



73/23/EEC
89/336/EEC
92/31/EEC
93/68/EEC

Table of Contents

Specifications	5
Before Installation	6
Unpacking	7
Name and Location	7
Wall Mounting	8
Opening Front Cover	8
Frame Ground Connection	8
System Connection Diagram	9
CO Line Connection	10
Extension Connection	11
Paralleled Telephone Connection	12
Installation of Optional Card and Unit	13
Installation of Lightning Protectors	15
Power Failure Transfer	17
Starting the System	17
General Programming Instructions	18
System Programming	19
System Speed Dialing Number Set	19
Dial Type Selection	19
Outgoing Permitted CO1 Assignment (Day/Night)	19
Outgoing Permitted CO2 Assignment (Day/Night)	20
CO1 Ringing Assignment (Day/Night)	20
CO2 Ringing Assignment (Day/Night)	20
Doorphone Assignment (Day/Night)	21
Toll Restriction (TRS) – Class Assignment (Day/Night)	21
TRS Denied Code (CLASS 2, 3)	22
TRS Denied Code (CLASS 3)	22
OGM Recording	22
OGM Play	23
Fax Connection	23
CO1 Delayed Ringing Assignment	23
CO2 Delayed Ringing Assignment	24
Delayed Ringing Count Selection	24
TRS Excepted Code	24
Day/Night Switching Mode	25
Day/Night Starting Time	25
System Data Clear	25
Other programs	26
Tone / Ring Tone	28
Programming Tables	30
Templet	33

Specifications

General Descriptions

1. Capacity	CO line Extension	2 6
2. Control Method	Stored Program CPU: 8 bits CPU Control ROM: 64 KB, Control RAM: 8 KB	
3. Switching Method	Space Division CMOS Crosspoint Switch	
4. Power Supplies	Primary Secondary Power Failure	AC 110–240 V, 50/60 Hz Circuit Volt: +5V, +15 V, +30 V CO 1 assigned to extension 21 CO 2 assigned to extension 22
5. Dialing	Outward Internal Mode Conversion	Dial Pulse 10 PP Tone Dial Dial Pulse 10 PPS, 20 PPS Tone Dial DP-DTMF, DTMF-DP
6. Connector	CO Extension Doorphone	4-pin connector 4-pin connector 4-pin connector
7. EXT Connection	Cable	1 pair wire (single line telephone) 2 pair wire (proprietary telephone)
8. Intercom paths	2 (including the doorphone path)	

Characteristics

1. Station Loop Limit	Proprietary telephone Single line telephone Doorphone	40 ohms 600 ohms including set 20 ohms
2. Minimum Leak Resistance	15000 ohms	
3. Maximum Number of Station Instruments per line	1 (proprietary telephone) or 3 (single line telephone)	
4. Ring Voltage	90 Vrms at 25 Hz depends on Ringing Load	
5. Primary Power	AC 110–240 V, 50/60 Hz, 0.5 A maximum	
6. Central Office Loop Limit	1600 ohms maximum	
7. Environmental Requirements ...	0–40°C, 10%–90% (Humidity)	
8. Hookswitch Flash Timing Range	50-130 msec	

Before Installation

Please read the following notes concerning installation and connection before installing the system.

Safety Installation Instructions

When installing telephone wiring, basic safety precautions should always be followed to reduce the risk of fire, electric shock and injury to persons, including the following:

1. Never install telephone wiring during a lightning storm.
2. Never install telephone jacks in wet locations unless the jack is specifically designed for wet locations.
3. Never touch uninsulated telephone wires or terminals unless the telephone line has been disconnected at the network interface.
4. Use caution when installing or modifying telephone lines.

Installation Precautions

This set is exclusively made for wall mounting only. Avoid installing in the following places. (Doing so may result in malfunction, noise, or discoloration.)

1. In direct sunlight and hot, cold, or humid places. (Temperature range: 0°C-40°C/32°F-104°F)
2. Sulfuric gases produced in areas where there are thermal springs, etc. may damage the equipment or contacts.
3. Places in which shocks or vibrations are frequent or strong.
4. Dusty places, or places where water or oil may come into contact with the unit.
5. Near high-frequency generating devices such as sewing machines or electric welders.
6. On or near computers, telexes, or other office equipment, as well as microwave ovens or air conditioners. (It is preferable not to install in the same room with the above equipment.)
7. Install at least 1.8 m (6 feet) from radios and televisions. (both the main unit and a proprietary telephone)
8. Do not obstruct area around the main unit (for reasons of maintenance and inspection – be especially careful to allow space for cooling above and at the sides of the main unit).

Wiring Precautions

Make sure to keep the following instructions when wiring.

1. Do not wire the telephone cable in parallel with an AC power source, computer, telex, etc. If the cables are run near those wires, shield the cables with metal tubing or use shielded cables and ground the shields.
2. If cables are run on the floor, use protectors or the like to protect the wires where they may be stepped on. Avoid wiring under carpets.
3. Avoid using the same power supply outlet for computers, telexes, and other office equipment. Otherwise, the KX-T206's system operation may be interrupted by the induction noise from such equipment.
4. Please use one pair telephone wire for extension connection of (telephone) equipment such as standard telephones, answering machines, etc., except proprietary telephones (KX-T7130, KX-T7030, KX-T7020, KX-T7050, KX-T7055, etc.).
5. The AC cord must be plugged off during wiring. After all the wirings are completed, plug the AC cord into an AC outlet.
6. Mis-wiring may cause the system to operate improperly.
7. If an extension does not operate properly, disconnect the telephone from the extension line and then connect again, or plug off the AC cord of the system and then on again.
8. The KX-T206 is equipped with a 3-wire grounding type plug. This is a safety feature. If you are unable to insert the plug into the outlet, contact your electrician to replace your obsolete outlet. Do not defeat the purpose of the grounding-type plug.
9. Use twisted pair cable for CO line connection.
10. CO lines should be installed with lightning protectors. For details, see pages 15-17.

Unpacking

- Main Unit one
- AC Cord one
- Screw and Washer three
- 4-pin Plug eight

Name and Location

Overview of the Main Unit

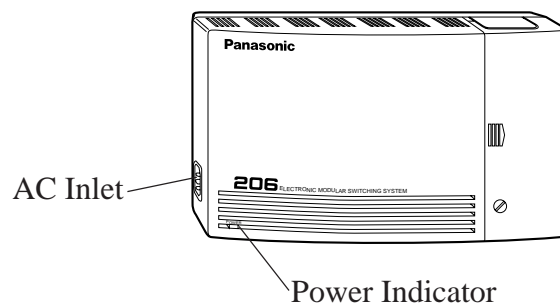

Inside View of the Main Unit

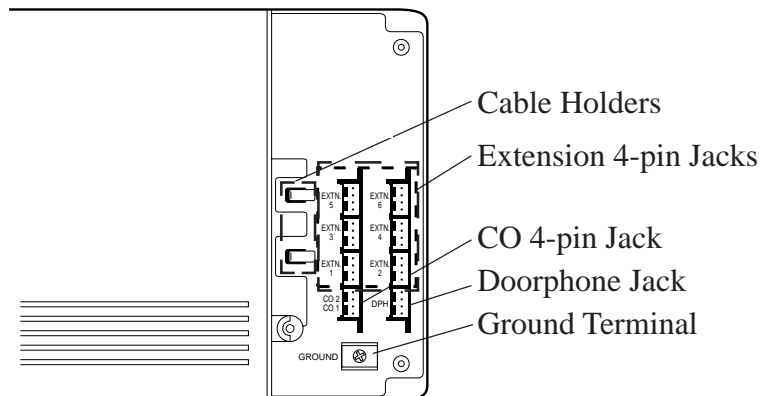

Wall Mounting

1. Place the templet (on page 33) on the wall to mark the three screw positions.

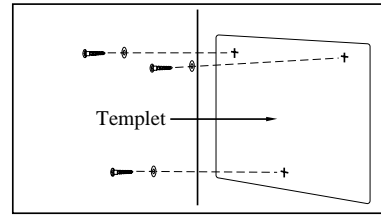

2. Install the three screws and washers (included) into the wall.
3. Hook the main unit on the screw heads.

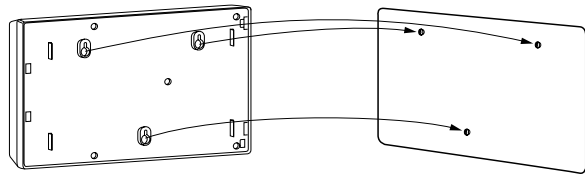

Opening Front Cover

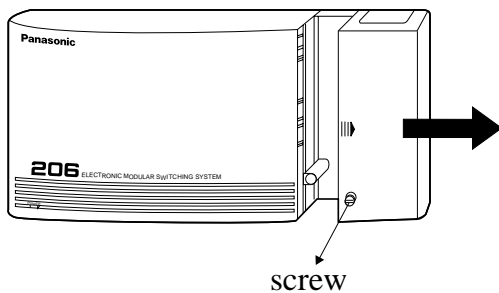

1. Loosen the screw.
2. Slide the cover in the direction of the arrow while pressing the marked position.

Frame Ground Connection

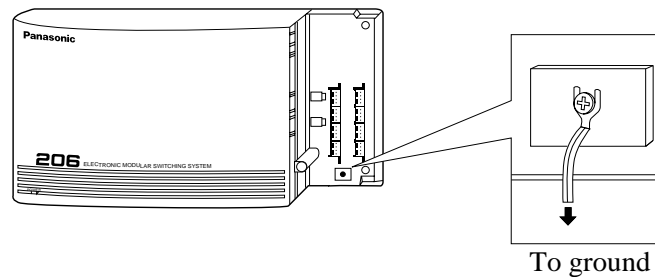

IMPORTANT!!!

Connect the frame of the main unit to ground.

System Connection Diagram

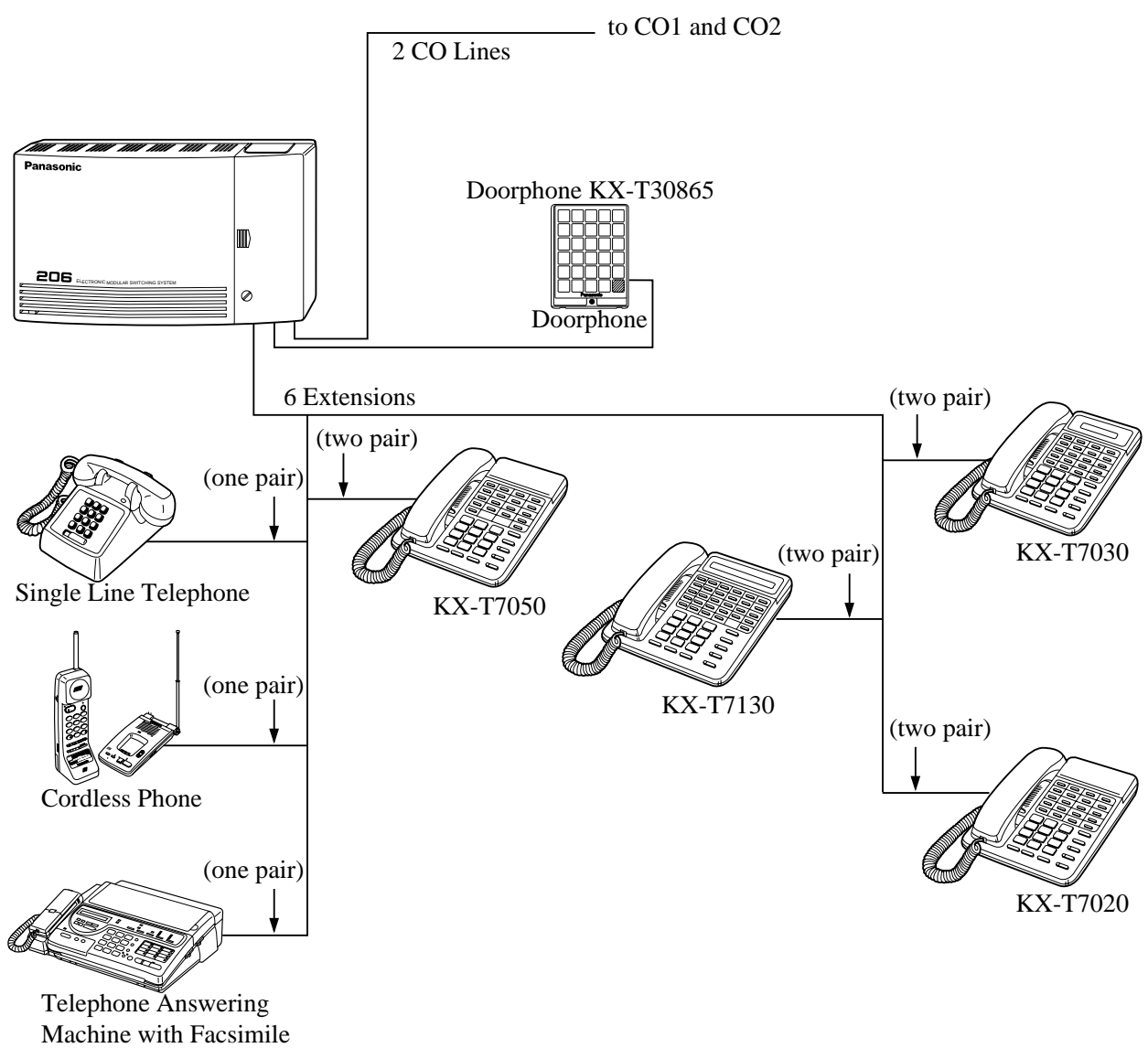

CO Line Connection

Wire Specification

The wire specifications are as follows:

Wire	Solid wire
Diameter of conductor	0.4 – 0.65mm (22, 24, 26 AWG)
Diameter with coating	0.66 – 1.05mm

Connection

Use a 4-pin plug (included) to connect CO lines.

A single plug is able to connect two CO lines. Use twisted pair cable.

1. Lift the transparent part.
2. Insert the required telephone wires into the holes of the plug.
Then press the transparent part back into the black part.

Note: Do not strip the wires.
Insert the wires all the way into the plug.

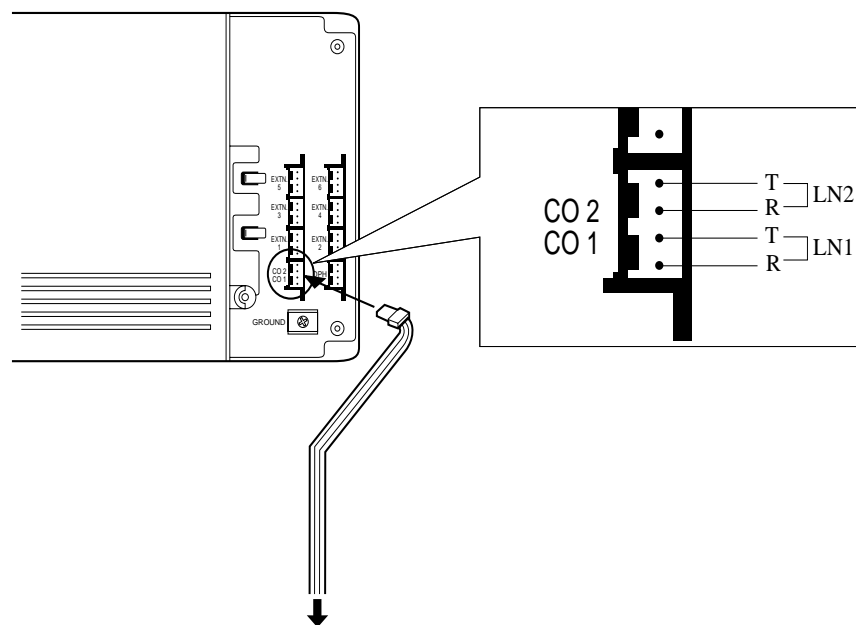
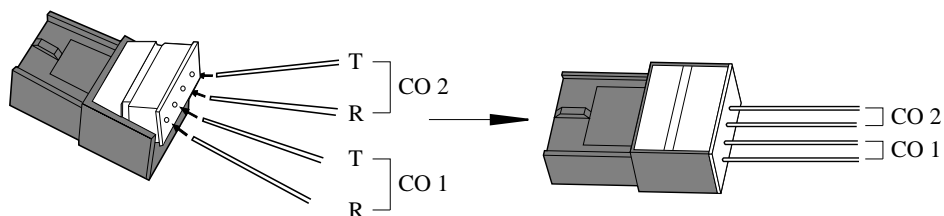

To Modular Jacks from
the Central Office

Note

- You can use cable holders to fix the wires.

Extension Connection

Wire Specification

The wire specifications are as follows:

Wire	Solid wire
Diameter of conductor	0.4 – 0.65mm (22, 24, 26 AWG)
Diameter with coating	0.66 – 1.05mm

Connection

Use a 4-pin plug (included) to connect extension lines.

There are 6 plugs to connect extensions to EXTN. 1 through EXTN. 6 jacks.

1. Lift the transparent part.
2. Insert the required telephone wires into the holes of the plug.
Then press the transparent part back into the black part.

Note: Do not strip the wires.

Insert the wires all the way into the plug.

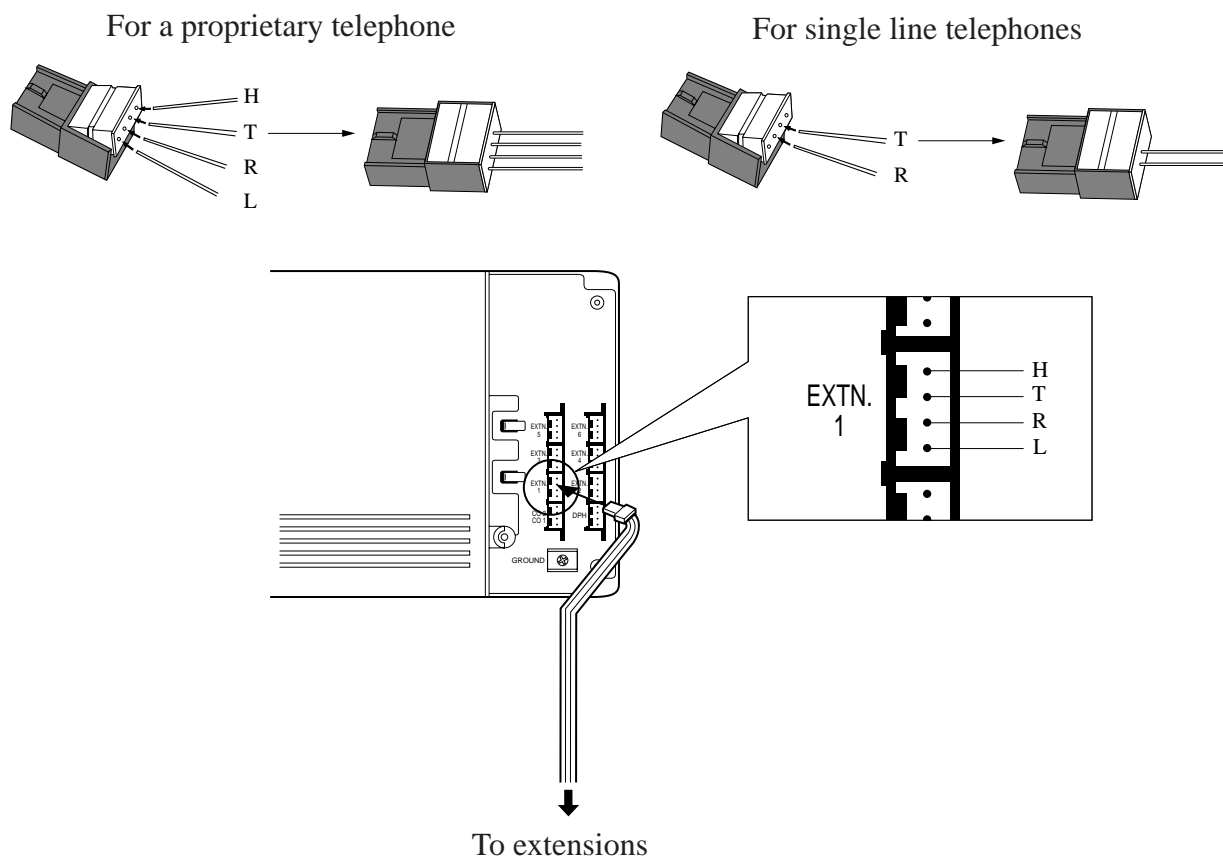

Notes

- A facsimile must be connected to EXTN.6 jack if an optional DISA/FAX Detect card (KX-T20691) is installed. See page 14 to install the card. System programming is also required. The “#12 Fax Connection” program should be assigned as “ENABLE”. See page 23. The “#24/#78 Call Incoming Mode Selection (Day / Night)” program should be assigned as “DISA”. See page 26.
- The EXTN.1 through EXTN.6 jacks correspond to extension numbers 21 through 26 respectively.
- You can use cable holders to fix the wires.

Paralleled Telephone Connection

Any single line telephone can be connected in parallel with a proprietary telephone.

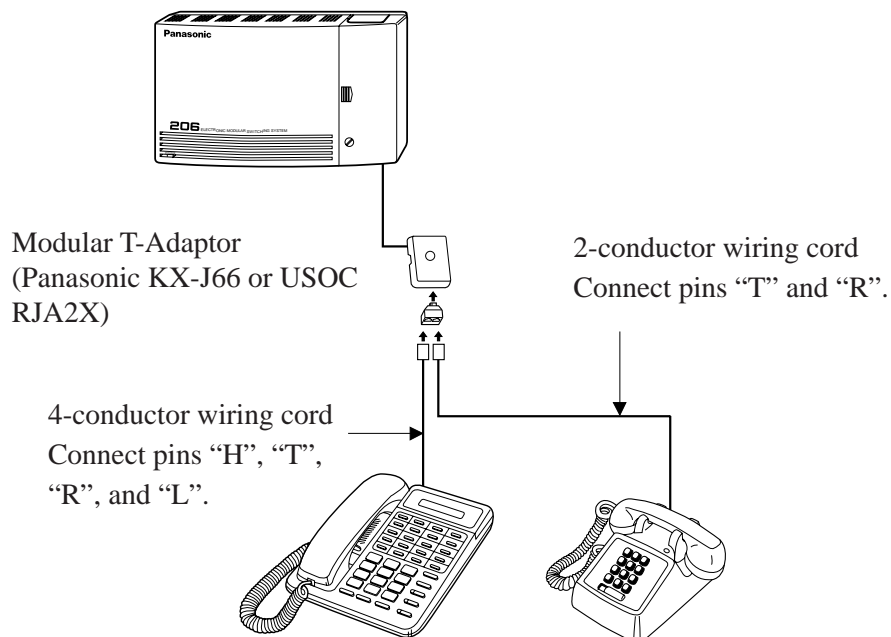

Notes

- System programming is required. See “#31 Paralleled Telephone Connection” on page 26.
- The following features are not available for SLT connected in parallel:
 - Call Splitting
 - External Feature Access
 - Conference

Installation of Optional Card and Unit

Doorphone (KX-T30865) Connection

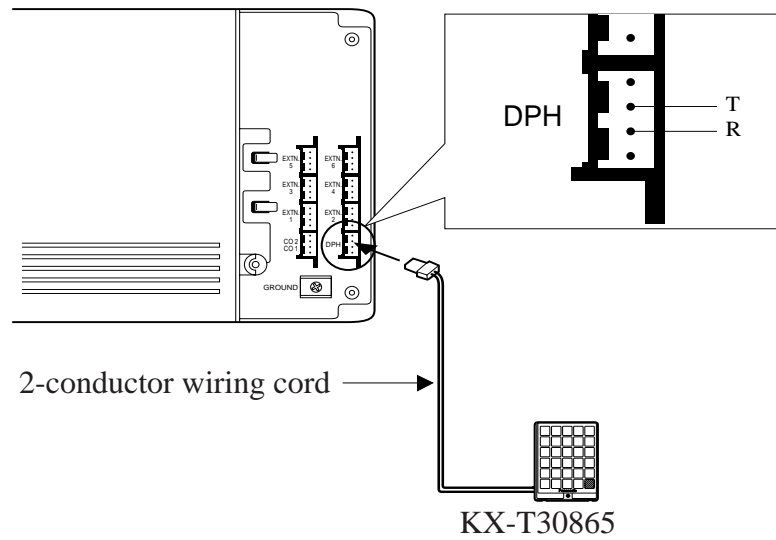

Notes

- The doorphone adaptor is not required for KX-T206.
- To avoid howling, you must assign all extensions as “DISABILITATO” in the “#06/#76 Doorphone Assignment (Day/Night)” program when you do not connect a doorphone.
- If howling occurs while using the doorphone feature, check the wiring.
- You can use cable holders to fix the wires.

Installation of Optional Card and Unit

DISA Card (KX-T20691) Connection

1. Disconnect the AC cord from the system.
2. Loosen the screws and remove the cover.
3. Attach the DISA card to the marked connectors.

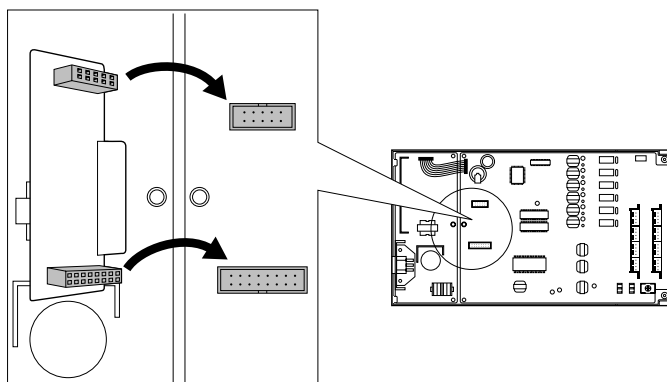
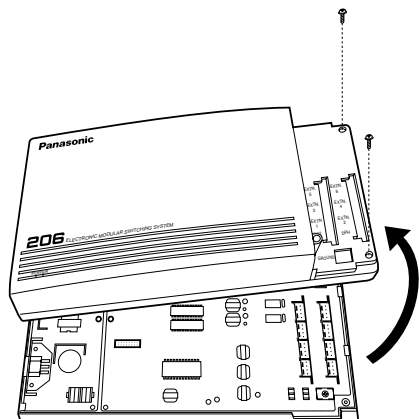

4. Replace the cover and secure the screws.
5. Connect the AC cord again.

The DISA feature allows an outside caller to have direct access to intercom calls. System programming is required. See “#10 OGM Recording” on page 22 and “#24/#78 Call Incoming Mode Selection (Day/Night)” on page 26.

Keep the following conditions in mind:

- When a caller enters the second digit of an extension number (1 through 6) during the message, he/she can reach the extension directly.
- If the call is not received, the assigned extensions will ring. See “#04/#74 CO1 Ringing Assignment (Day/Night), “#05/#75 CO2 Ringing Assignment (Day/Night)” on page 20 and “#60 DISA Ringing Time” on page 27.
- If the caller enters 7, 8, 9 or 0, or enters nothing, the assigned extensions can receive his/her call. See “#04/#74 CO1 Ringing Assignment (Day/Night), “#05/#75 CO2 Ringing Assignment (Day/Night)” on page 20.
- Any calls from a rotary phone will be received by the extensions assigned in the programs “#04/#74 CO1 Ringing Assignment (Day/Night), and “#05/#75 CO2 Ringing Assignment (Day/Night)” on page 20.

Installation of Lightning Protectors

Overview

A lightning protector is a device to be installed on a CO line to prevent a dangerous surge from entering the building and damaging equipment. A dangerous surge can occur if a telephone line comes in contact with a power line. Trouble due to lightning surges have been showing a steady increase with the development of electronic equipment. In many countries, there are regulations requiring the installation of a lightning protector. A lightning strike to a telephone cable which is 10 m (33 feet) above ground can be as high as 200,000 volts. This system should be installed with lightning protectors. In addition, grounding (connection to earth ground) is very important for the protection of the system.

Recommended lightning protector

- Panasonic KX-A207

Installation

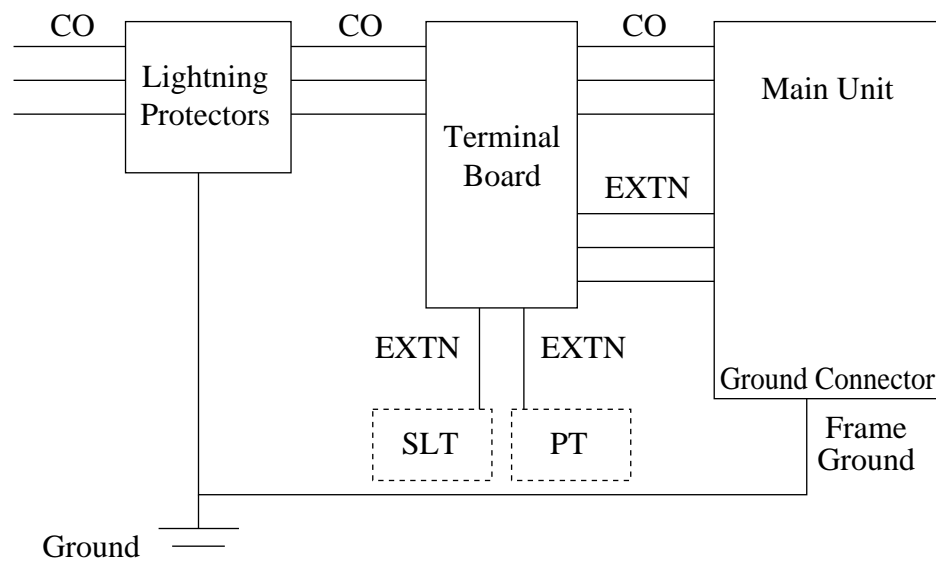

Installation of Lightning Protectors

Outside

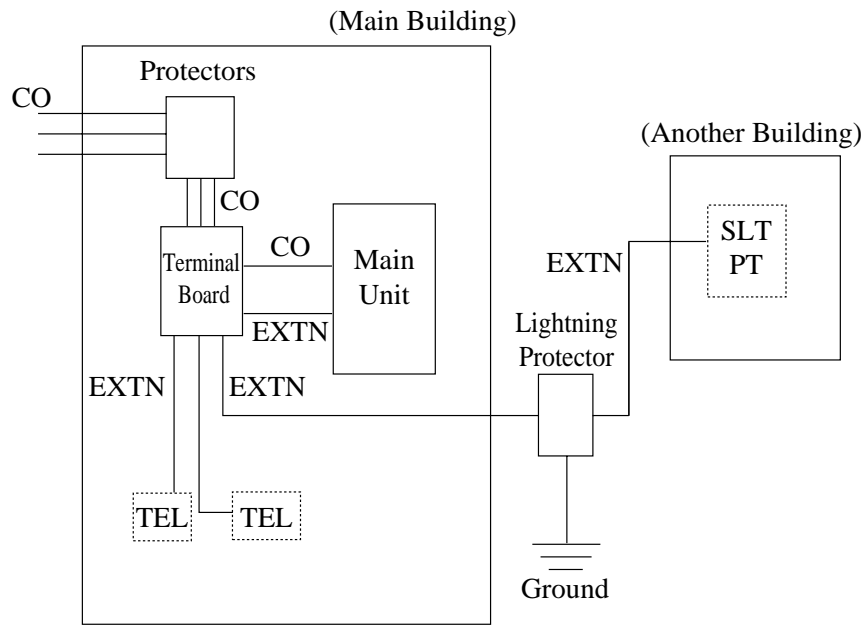

Notice

If you install an extension outside of the main building, the following precautions are recommended:

- (1) Install the extension wire underground.
- (2) Use a conduit to protect the wire.

Note

- The lightning protector for an extension is different from that for CO.

Installation of an Earth Rod

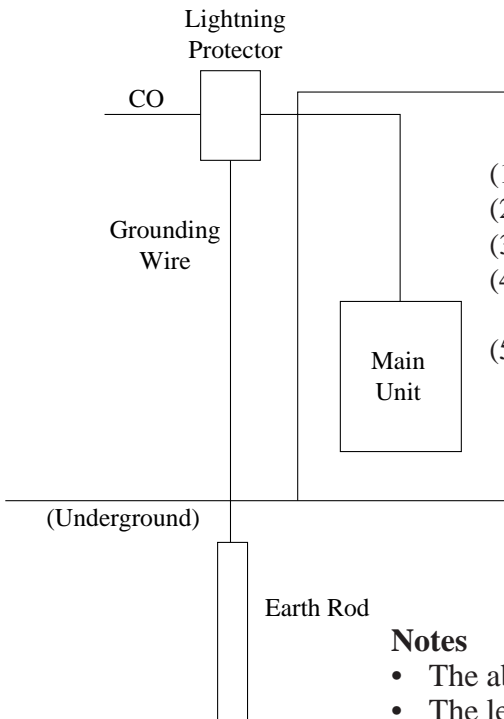

- (1) Installation location of the earth rod Near the protector
- (2) Check obstructions None
- (3) Composition of the earth rod Metal
- (4) Depth of the earth rod More than 50 cm
(20 inches)
- (5) Size of the grounding wire Thickness is greater
than 16 AWG

Notes

- The above figures are recommendations only.
- The length of earth rod and the required depth depend on the composition of the soil.

Installation of Lightning Protectors

Installation of the KX-A207

1. Secure the protector to a building with the enclosed mounting screws.
4. Fold the external and internal cables, and connect them to the terminal screws using washers.

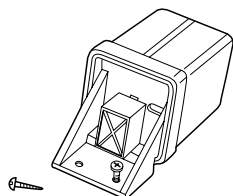

2. Remove about 1 cm ($13/32$ inch) of insulation from the end of the earth wire. Insert the earth wire through the bottom of the protector base and secure it to the earth terminal.

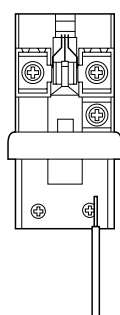

3. Remove about 1.5 cm ($19/32$ inch) of insulation from the ends of the external and internal cables, then pass the cables through the rubber packing.

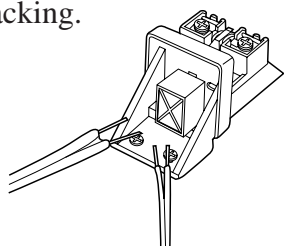

5. Secure the external and internal cables and the earth wire to the building. Then, install the arrester and mount the cover on the protector.

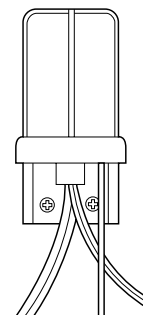
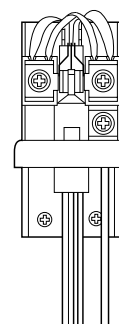

Power Failure Transfer

In the event of a power failure, CO1 is connected to extension 21 and CO2 is connected to extension 22 automatically.

Note

- The system programmed data is protected by the factory provided lithium battery.

Starting the System

Plug the AC power cord into the system and an AC outlet.

- The power indicator of the system will light.

General Programming Instructions

Default Setting	<p>This system has a default factory setting. If any of the programming needs to be changed, you can change the setting by system programming.</p>
Required Telephone Set	<p>You can use any of the following telephones for system programming:</p> <ul style="list-style-type: none">• Proprietary Telephone (PT): KX-T7130, KX-T7030, KX-T7020, KX-T7050, KX-T7055• Single Line Telephone (SLT): tone type <p>All telephones (except KX-T7130 and KX-T7030) do not have display panels, so you cannot check the setting you have made. Therefore, please use KX-T7130 or KX-T7030 to check the programming.</p>
Extensions Used for Programming	<p>System programming can only be performed from extension 21.</p>
To Check the Programmed Data	<p>Use KX-T7130 or KX-T7030. When you check the assignment, set the MEMORY switch on PT to “PROGRAM”.</p> <p>Enter “#” and the program address.</p> <p>You cannot check programs #60, #62, #63, #65, #66 and #69, as they are not displayed on the display panel.</p>
Before Programming	<p>To enter the system programming mode:</p> <p>[Off-hook] <input type="text" value="6"/> <input type="text" value="2"/> <input type="text" value="0"/> <input type="text" value="6"/> <input type="text" value="2"/> <input type="text" value="0"/> <input type="text" value="6"/> <input type="text" value="#"/></p>
After Programming	<p>To exit the system programming mode:</p> <p>[Off-hook] <input type="text" value="6"/> <input type="text" value="2"/> <input type="text" value="0"/> <input type="text" value="6"/> <input type="text" value="#"/></p>

System Programming

System Speed Dialing Number Set

Description

Used to program System Speed Dial numbers. These numbers are available to all extension users. There are 80 numbers from 00 through 79.

Condition

- A maximum of 32 digit numbers can be stored.
- You must store an automatic line access code (0 or 9), or an individual line code (81 or 82) first. The automatic line access code is assigned in “#52 CO Line Access Number Selection”.
- If you store a pause, press *.

Input Format

0 0 [AA] [Phone No.]

Explanation

- [AA]=Speed dial number: 00 through 79
- Phone number: 32 digits max.

Default NO REGISTRAZ

Dial Type Selection

Description

Assigns the Dial Type (tone or pulse) to CO line.

Input Format

0 1 [A] [B]

Explanation

- [A]= 1: LU1/ 2: LU2
- [B]= 0: DECADICO/ 1: TONI

Default Both COs– 0: DECADICO

Outgoing Permitted CO1 Assignment (Day/Night)

Description

Determines the extensions which can have access to CO line 1 in both day and night modes. The extension users can make outgoing CO calls if their extensions are assigned as “ABILITATO”.

Input Format

0 2 (for day) / 7 2 (for night) [A] [B]

Explanation

- [A]= 1 through 6 (corresponding to extension no. 21 through 26)
- [B]= 0:DISABILITATO/ 1: ABILITATO

Default All extensions– 1: ABILITATO

System Programming

Outgoing Permitted CO2 Assignment (Day/Night)

Description

Determines the extensions which can have access to CO line 2 in both day and night modes. The extension users can make outgoing CO calls if their extensions are assigned as “ABILITATO”.

Input Format

0 3 (for day) / 7 3 (for night) [A] [B]

Explanation

- [A]= 1 through 6 (corresponding to extension no. 21 through 26)
- [B]= 0: DISABILITATO/ 1: ABILITATO

Default All extensions– 1: ABILITATO

CO1 Ringing Assignment (Day/Night)

Description

Assigns the extensions which will ring when a call from CO line 1 is received in both day and night modes.

Input Format

0 4 (for day) / 7 4 (for night) [A] [B]

Explanation

- [A]= 1 through 6 (corresponding to extension no. 21 through 26)
- [B]= 0:DISABILITATO (not ring)/ 1: ABILITATO (ring)

Default extension 21–1: ABILITATO other extensions– 0:DISABILITATO

CO2 Ringing Assignment (Day/Night)

Description

Assigns the extensions which will ring when a call from CO line 2 is received in both day and night modes.

Input Format

0 5 (for day) / 7 5 (for night) [A] [B]

Explanation

- [A]= 1 through 6 (corresponding to extension no. 21 through 26)
- [B]= 0:DISABILITATO (not ring)/ 1: ABILITATO (ring)

Default extension 21–1: ABILITATO other extensions– 0:DISABILITATO

System Programming

Doorphone Assignment (Day/Night)

Description

Assigns the extensions which will ring when a doorphone call is received and enables to call the doorphone in both day and night modes.

Condition

- All extensions must be assigned as “0: DISABILITATO”, if you do not connect a doorphone to the system.

Input Format

0 6 (for day) / 7 6 (for night) [A] [B]

Explanation

- [A]= 1 through 6 (corresponding to extension no. 21 through 26)
- [B]= 0:DISABILITATO/ 1: ABILITATO

Default All extensions– 1: ABILITATO

Toll Restriction (TRS) – Class Assignment (Day/Night)

Description

Assigns a Toll Restriction Class to each extension in both day and night modes. The Toll Restriction feature can prohibit certain extension users from placing unauthorized toll calls. The following four classes are available:

Class	Restricted calls
CLASS 1	None
CLASS 2	Numbers programmed in “#08 Denied code (Class 2, 3)”
CLASS 3	Numbers programmed in “#08 Denied code (Class 2, 3) and “#09 Denied code (Class 3)”
CLASS 4	All CO calls

Input Format

0 7 (for day) / 7 7 (for night) [A] [B]

Explanation

- [A]= 1 through 6 (corresponding to extension no. 21 through 26)
- [B]= 1: CLASSE 1/ 2: CLASSE 2/ 3: CLASSE 3/ 4: CLASSE 4

Default All extensions– 1: CLASSE 1

System Programming

TRS Denied Code (CLASS 2, 3)

Description

Allows you to specify the numbers which are toll-restricted for TRS Class 2 and Class 3.

Condition

- The character “*” can be any number.

Input Format

0 8 [A] [Denied code No.]

Explanation

- [A]= Code No.: 0 through 9 1 digit
- Denied code number: 7 digits, *

Default All codes– NO REGISTRARZ

TRS Denied Code (CLASS 3)

Description

Allows you to specify the numbers which are toll-restricted for TRS Class 3.

Condition

- The character “*” can be any number.

Input Format

0 9 [A] [Denied code No.]

Explanation

- [A]= Code No.: 0 through 9 1 digit
- Denied code number: 7 digits, *

Default All codes– NO REGISTRARZ

OGM Recording

Description

Used to record an outgoing message for Direct Inward System Access (DISA).

Condition

- The recording time is a maximum of 16 seconds.
- If you perform programming with a PT, the message “REGISTRAZIONE” will be displayed on its panel.
- If the DISA/FAX Detect card is not installed, you will hear a reorder tone and the program is finished.

Message example: “This is AAA company. Please enter 1 for Mr. AA, 2 for Mr. BB
6 for Ms. FF. Thank you.”

Input Format

1 0 (Record your message)

System Programming

OGM Play

Description

Confirms the outgoing message recorded in the OGM Recording program.

Condition

- If you perform programming with a PT, the message “ASCOLTO” will be displayed on its panel.

Input Format

1 1

Fax Connection

Description

Allows the system to detect the CNG tone from a facsimile. If it is set to “ABILITATO”, extension 26 will receive fax transmission data.

Condition

- The optional DISA/FAX Detect card (KX-T20691) should be installed.
- The “#24/#78 Call Incoming Mode Selection (Day/Night)” program should be assigned as “DISA”.
- Extension 26 should be assigned as “DISABILITATO” in the “#04/#74 CO1 Ringing Assignment (Day/Night)”, “#05/#75 CO2 Ringing Assignment (Day/Night)” and “#06/#76 Doorphone Assignment (Day/Night)” programs.

Input Format

1 2 [A]

Explanation

- [A]= 0:DISABILITATO (not detect)/ 1: ABILITATO (detect)

Default 0:DISABILITATO

CO1 Delayed Ringing Assignment

Description

Assigns delayed ringing to extensions when a call from CO line 1 is received.

Condition

- The number of delayed rings is assigned by the “#15 Delayed Ringing Count Selection” program.
- This feature is not available for the calls sent by the DISA feature.

Input Format

1 3 [A] [B]

Explanation

- [A]= 1 through 6 (corresponding to extension no. 21 through 26)
- [B]= 0:DISABILITATO (not delayed)/ 1: ABILITATO (delayed)

Default All extensions– 0:DISABILITATO

System Programming

CO2 Delayed Ringing Assignment

Description

Assigns delayed ringing to extensions when a call from CO line 2 is received.

Condition

- The number of delayed rings is assigned by the “#15 Delayed Ringing Count Selection” program.
- This feature is not available for the calls sent by the DISA feature.

Input Format

1 4 [A] [B]

Explanation

- [A]= 1 through 6 (corresponding to extension no. 21 through 26)
- [B]= 0: DISABILITATO (not delayed)/ 1: ABILITATO (delayed)

Default All extensions– 0:DISABILITATO

Delayed Ringing Count Selection

Description

Assigns the number of delayed rings that will be sent to the assigned extensions from the CO lines.

Input Format

1 5 [A]

Explanation

- [A]= 1: DOPO 1 RING/ 2: DOPO 2 RING/ 3: DOPO 3 RING/
4: DOPO 4 RING

Default 2: DOPO 2 RING

TRS Excepted Code

Description

Allows you to assign numbers which are exceptions to the toll restriction specified in programs [08] and [09]. You can assign a maximum of 10 codes.

Explanation

- The character “*” can be any numbers.

Input Format

1 6 [A] [Excepted code No.]

Explanation

- [A]= Code No.: 0 through 9 1 digit
- Excepted number: 7 digits, *

System Programming

Day/Night Switching Mode

Description

Assigns automatic or manual day/night mode.

Condition

- If automatic switching mode is assigned, day/night mode is switched at the time programmed in “#71 Day/Night Starting Time”.

Input Format

7 0 [A]

Explanation

- [A]= 0: MANUALE/ 1: AUTO

Default 0: MANUALE

Day/Night Starting Time

Description

Sets the starting time when automatic day/night mode is programmed in the “#70 Day/Night Switching Mode” program.

Input Format

7 1 [A] [BB] [CC]

Explanation

- [A]= 1: Day start time / 2: Night start time
- [BB]= Hour: 00-23
- [CC]=Minute: 00-59

Default Day– 9:00 Night–17:00

System Data Clear

Description

Allows the system to re-initialize the system-programmed data. The features mentioned in “Station Feature Clear” are also re-initialized. See page 12 of the User Manual. When all the programmed data is cleared, the system will restart with the default setting.

Input Format

9 9

System Programming

Other Programs

• Call Blocking Mode Setting

Assigns whether or not to prevent the DTMF signal from being sent to a CO line. This feature is useful when a Central Office in your country accepts both tone and pulse signals or when you have access to your host PBX with a pulse dial.

Input Format: #20 [A]

- [A]=0:DISABILITATO(default)/ 1: ABILITATO

• Host PBX Access Code Assignment

Assigns a Host PBX access code to make an outside call, if the system is installed behind the host PBX. A pause is automatically inserted after the access code and the toll restriction feature applies to the number after the code.

Input Format: #21 [A] [code] #

- [A]=1: LU1/ 2: LU2
- [code] = 2 digits max. (Default : NO REGISTRASZ)

• Hookswitch Flash Time Assignment

Sets the time to send the flash signal to each CO line.

Input Format: #22 [A] [B]

- [A]=1: LU1/ 2: LU2
- [B]=0: 80 MS/ 1: 100 MS (default)/ 2: 160 MS/ 3: 300 MS/ 4: 600 MS / 5: 900 MS/ 6: 1200 MS

• CO Pulse Selection

Assigns to send the pulse to CO line during a conversation with an outside party when the “#01 Dial Type Selection” program is assigned as “Pulse”.

Input Format: #23 [A]

- [A]=0:DISABILITATO/ 1: ABILITATO (default)

• Call Incoming Mode Selection (Day/Night)

Assigns whether to use the DISA feature or not. This program is available when the DISA/FAX Detect card is installed.

Input Format: #24 (for day)/#78 (for night) [A] [B]

- [A]=1: CO1/ 2: CO2
- [B]=0: NORMAL/ 1: DISA (default)

• Bell Off Detection

Sets the time between one bell signal detection and the next signal from a Central Office.

Input Format: #25 [A]

- [A]=1: 6 SEC (default)/ 2: 12 SEC

• Intercom Alerting Assignment

Assigns the intercom alerting mode to each extension when an intercom call reaches.

Input Format: #30 [A] [B]

- [A]=1 through 6 (corresponding to extension no. 21 through 26)

- [B]=0: TONO CHIAMATA(default)/ 1: CHIAMATA VOCE

• Paralleled Telephone Connection

Assigns whether each extension will be connected in parallel with a single line telephone or not.

Input Format: #31 [A] [B]

- [A]=1 through 6 (corresponding to extension no. 21 through 26)

- [B]=0:DISABILITATO (default)/ 1:ABILITATO

• Tone Waiting Time After OGM

Sets the time between sending an outgoing message and sending the ringback tone.

Input Format: #40 [A]

- [A]=0: 0 SEC/ 1: 5 SEC (default)/ 2: 10 SEC/ 3: 15 SEC

• Hold Recall Time

Assigns the length of the hold recall timer. The hold recall timer is used to alert an extension that a call has been held for an extended period of time.

Input Format: #50 [A]

- [A]=0: 0 SEC (default)/ 1: 1 MIN / 2: 2 MIN/ 3: 3 MIN/ 4: 4 MIN/ 5: DISABILITATO

• Hold Mode Selection for SLT

Assigns the method to put a call on hold with SLTs.

Input Format: #51 [A]

- [A]=1: MODO 1 (hooking) (default) 2: MODO 2 (hooking and dial 6)

• CO Line Access Number Selection

Selects the automatic line access number.

Input Format: #52 [A]

- [A]=1: 9/ 2: 0 (default)

• Transfer Recall Time

The transfer recall timer is used to alert an extension that a transferred call has not been answered for an extended period of time.

Input Format: #54 [A]

- [A]=1: 30 SEC (default)/ 2: 2 MIN

• Music on Hold Use

Selects whether or not to use internal music as the music on hold.

Input Format: #55 [A]

- [A]=1: MODE 1 (NO MUSIC) / 2: MODE 2 (MUSIC)(default)

System Programming

Other Programs (continued)

- **DISA Ringing Time Assignment**

Sets the time to forward a call sent by the DISA feature to other extensions. If the call is not answered by the designated extension within the programmed time, the call is forwarded to extensions which are not assigned as “DISABILITATO” in the #04/#74 CO1 Ringing Assignment (Day/Night) and #05/#75 CO2 Ringing Assignment (Day/Night). If “DISABILITATO” is selected in this program, the telephone at the designated extension rings for 60 seconds and the call is not forwarded.

Input Format: #60 [A]

- [A]=0: DISABILITATO / 1: 10 SEC/
2: 20 SEC (default)/ 3: 35 SEC

- **Toll Restriction Code Check**

Assigns whether “*” or “#” is to be checked or not when a user dials them in the Toll Restriction code.

Input Format: #62 [A]

- [A]=0:DISABILITATO/
1: ABILITATO (default)

- **CO Indicator Assignment**

Assigns whether an incoming CO call indicates or not on the CO button. Also it allows an extension user to answer the call by pressing the CO button when “DISABILITATO” is selected in the #04/#74 “CO1 Ringing Assignment” or the #05/#75 “CO2 Ringing Assignment” program.

Input Format: #63 [A]

- [A]=0:DISABILITATO (The indicator lights red and a user cannot answer the call.)
1: ABILITATO (The indicator is flashing and a user can answer the call.)
(default)

- **Hookswitch Flash Time Range Assignment**

Sets the hookswitch flash time range.

Input Format: #65 [A]

- [A]=1: 80–1000MS / 2: 80–130MS
3 : 50–130MS (default)

- **Dial Start Time**

Sets the time the system waits before dialing after a CO lined is seized.

Input Format: #66 [A]

- [A]=1: 800 MS (default)/ 2: 2000 MS

Note

- You cannot check the assignments of the programs #60, #62, #63, #65, #66 and #69 by setting the MEMORY switch to “PROGRAM”, and entering “#” and the program address.

Tone / Ring Tone

<Tone>

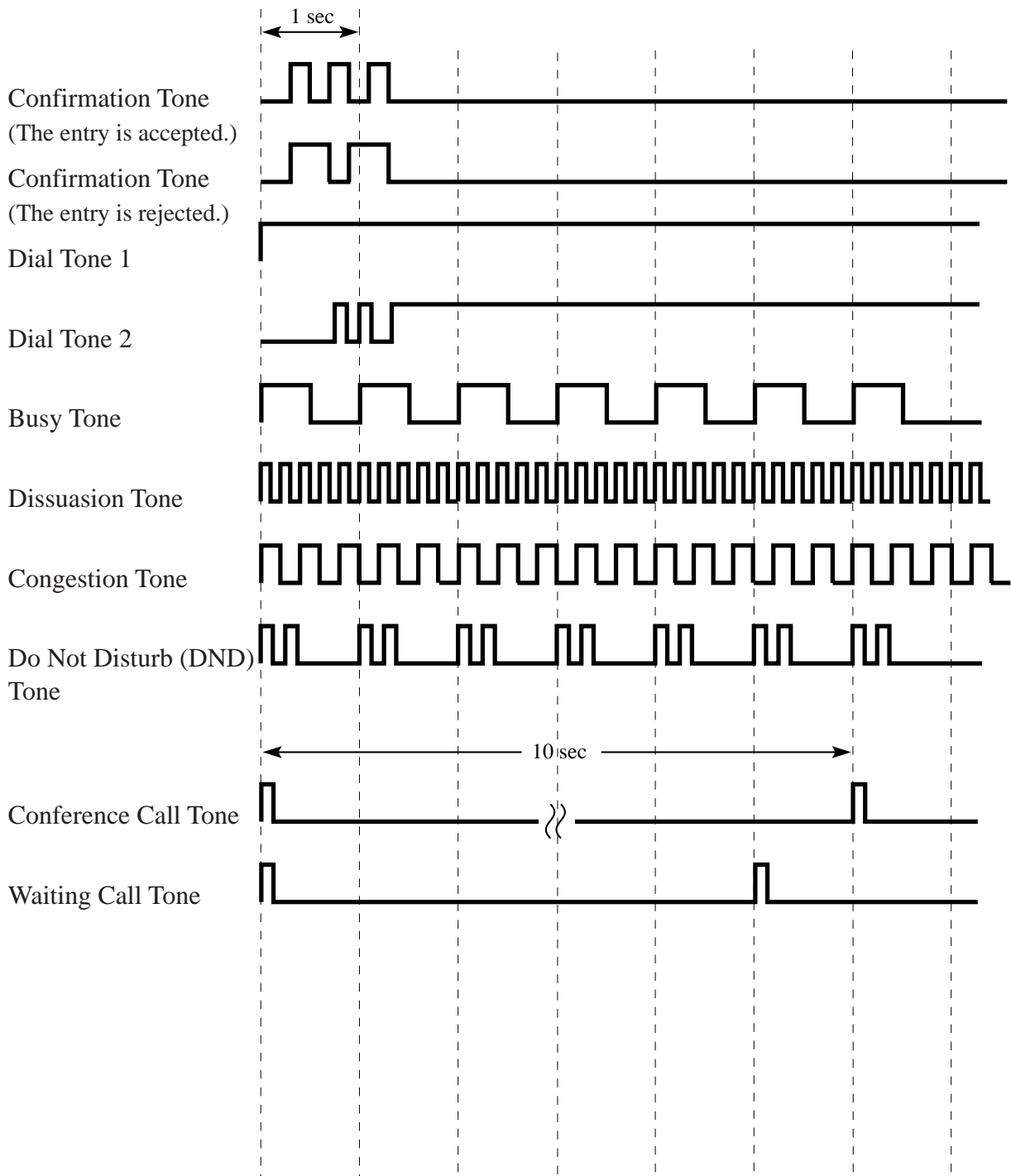

Tone / Ring Tone

<Ring Tone>

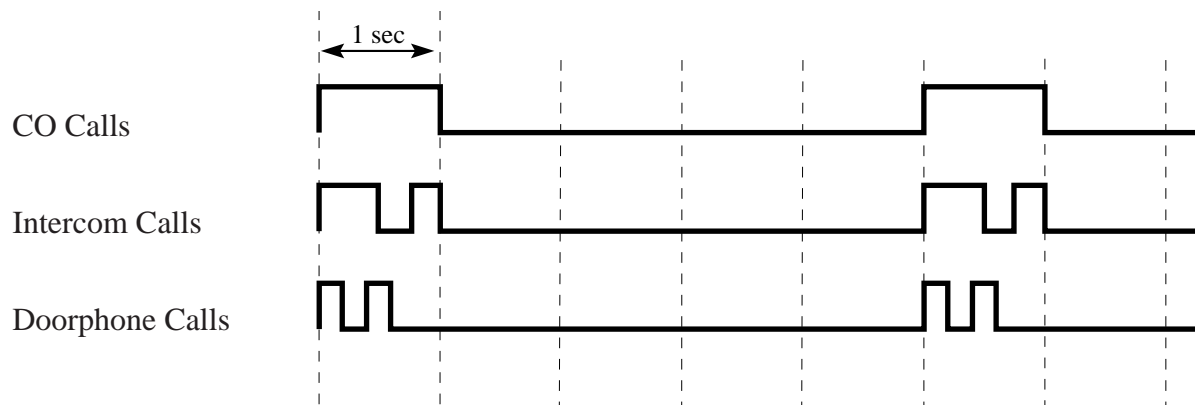

NOTE

- The dial tone 2 is heard during the system programming mode and when the following features are set:
 - Do Not Disturb
 - Call Pickup Deny
 - Call Forwarding
 - Data Line Security

Programming Tables

[#00] System Speed Dialing Number Set

No.	Name	Phone No. (32 digits max.)
00		
01		
02		
03		
04		
05		
06		
07		
08		
09		
10		
11		
12		
13		
14		
15		
16		
17		
18		
19		
20		
21		
22		
23		
24		
25		
26		
27		
28		
29		
30		
31		
32		
33		
34		
35		
36		
37		
38		
39		

Programming Tables

No.	Name	Phone No. (32 digits max.)
40		
41		
42		
43		
44		
45		
46		
47		
48		
49		
50		
51		
52		
53		
54		
55		
56		
57		
58		
59		
60		
61		
62		
63		
64		
65		
66		
67		
68		
69		
70		
71		
72		
73		
74		
75		
76		
77		
78		
79		

Programming Tables

#01] Dial Type Selection

	Default	LU1	LU2
0: DECADICO	✓		
1: TONI			

#12] Fax Connection

	Default	Selection
0: DISABILITATO	✓	
1: ABILITATO		

#70] Day/Night Switching Mode

	Default	Selection
0: MANUALE	✓	
1: AUTO		

#71] Day/Night Starting Time

	Default	Selection
1: DAY	9:00	
2: NIGHT	17:00	

#02] Outgoing Permitted CO 1 Assignment (Day)

	Default	Ext.21	Ext.22	Ext.23	Ext.24	Ext.25	Ext.26
0: DISABILITATO							
1: ABILITATO	✓						

#72] Outgoing Permitted CO 1 Assignment (Night)

	Default	Ext.21	Ext.22	Ext.23	Ext.24	Ext.25	Ext.26
0: DISABILITATO							
1: ABILITATO	✓						

#03] Outgoing Permitted CO 2 Assignment (Day)

	Default	Ext.21	Ext.22	Ext.23	Ext.24	Ext.25	Ext.26
0: DISABILITATO							
1: ABILITATO	✓						

#73] Outgoing Permitted CO 2 Assignment (Night)

	Default	Ext.21	Ext.22	Ext.23	Ext.24	Ext.25	Ext.26
0: DISABILITATO							
1: ABILITATO	✓						

#04] CO 1 Ringing Assignment (Day)

	Default	Ext.21	Default	Ext.22	Ext.23	Ext.24	Ext.25	Ext.26
0: DISABILITATO			✓					
1: ABILITATO	✓							

#74] CO 1 Ringing Assignment (Night)

	Default	Ext.21	Default	Ext.22	Ext.23	Ext.24	Ext.25	Ext.26
0: DISABILITATO			✓					
1: ABILITATO	✓							

#05] CO 2 Ringing Assignment (Day)

	Default	Ext.21	Default	Ext.22	Ext.23	Ext.24	Ext.25	Ext.26
0: DISABILITATO			✓					
1: ABILITATO	✓							

#75] CO 2 Ringing Assignment (Night)

	Default	Ext.21	Default	Ext.22	Ext.23	Ext.24	Ext.25	Ext.26
0: DISABILITATO			✓					
1: ABILITATO	✓							

#06] Doorphone Assignment (Day)

	Default	Ext.21	Ext.22	Ext.23	Ext.24	Ext.25	Ext.26
0: DISABILITATO							
1: ABILITATO	✓						

#76] Doorphone Assignment (Night)

	Default	Ext.21	Ext.22	Ext.23	Ext.24	Ext.25	Ext.26
0: DISABILITATO							
1: ABILITATO	✓						

#07] Toll Restriction (TRS) – Class Assignment (Day)

	Default	Ext.21	Ext.22	Ext.23	Ext.24	Ext.25	Ext.26
1: CLASSE 1	✓						
2: CLASSE 2							
3: CLASSE 3							
4: CLASSE 4							

#77] Toll Restriction (TRS) – Class Assignment (Night)

	Default	Ext.21	Ext.22	Ext.23	Ext.24	Ext.25	Ext.26
1: CLASSE 1	✓						
2: CLASSE 2							
3: CLASSE 3							
4: CLASSE 4							

#08] TRS Denied Code (CLASS 2, 3)

Code	Number (7 digits)
0	
1	
2	
3	
4	
5	
6	
7	
8	
9	

#09] TRS Denied Code (CLASS 3)

Code	Number (7 digits)
0	
1	
2	
3	
4	
5	
6	
7	
8	
9	

#13] CO 1 Delayed Ringing Assignment

	Default	Ext.21	Ext.22	Ext.23	Ext.24	Ext.25	Ext.26
0: DISABILITATO	✓						
1: ABILITATO							

#14] CO 2 Delayed Ringing Assignment

	Default	Ext.21	Ext.22	Ext.23	Ext.24	Ext.25	Ext.26
0: DISABILITATO	✓						
1: ABILITATO							

#16] TRS Excepted Code

Code	Number (7 digits)	Code	Number (7 digits)
0		5	
1		6	
2		7	
3		8	
4		9	

#15] Delayed Ringing Count Selection

	Default	Selection
1: 1 RING		
2: 2 RING	✓	
3: 3 RING		
4: 4 RING		

Templet

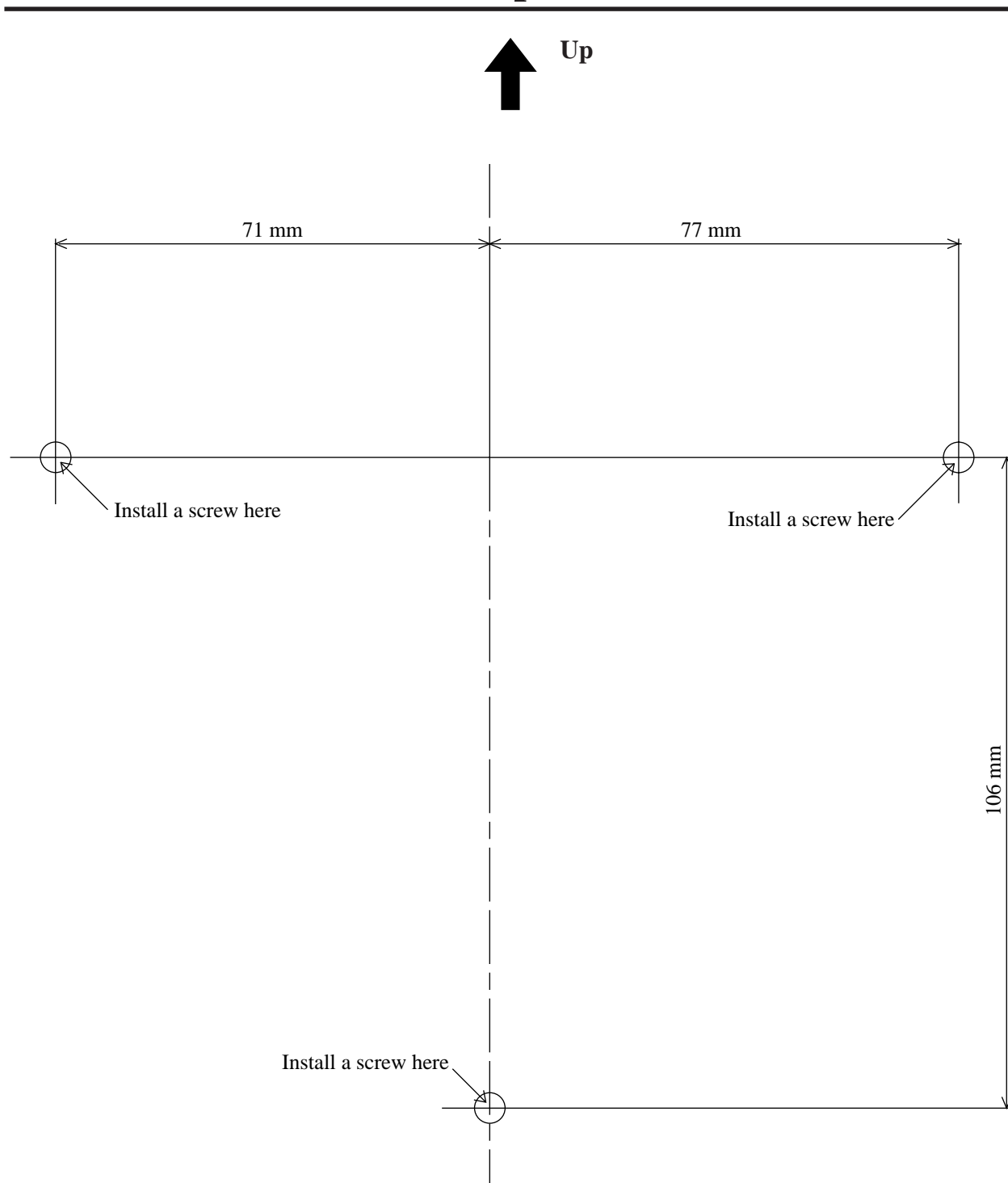

- Copy the templet and place it on the wall.

Matsushita Electric Industrial Co., Ltd.

Central P.O. Box 288, Osaka 530-91, Japan

Printed in Japan

PSQX1194ZA KW1097KM0